

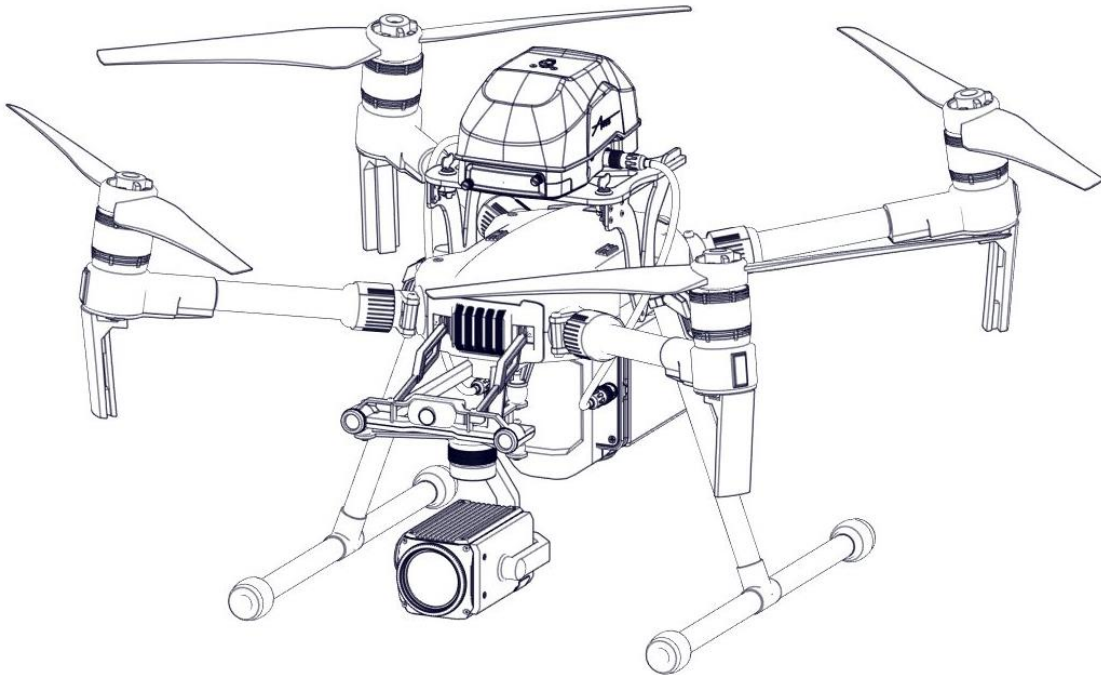

PRS-M200 for DJI M200 Series

Compatible with V1 and V2 of the DJI M200, M210, and M210 RTK

Version 2.0



Using this Manual

1. Revision Notes

Revision #	Date	Revision Description
1.0	October 10 th , 2019	- Initial release for ASTM-F3322-18
1.1	November 11 th , 2019	- Second draft version without updated photos
1.2	July 2 nd , 2020	- First public release
1.3	July 30 th , 2020	- Crash disclaimer - Manual remote range - Updated warning icon for the synchronization status - Added warning icon for the flight mode status
1.4	September 11 th , 2020	- New GPC case as a standard feature - Updated electronic module drawings - Updated FTS drawings - Updated remote range - Add Imperial units to product specifications
1.5	September 20 th , 2020	- Updated MaxTOW - Updated weight - Updated FTS drawings
1.6	October 13 th , 2020	- Updated AVSS MaxTOW descent rate - Updated AVSS MaxTOW impact energy - Updated firmware codes - Updated warranty replacement process
1.7	November 20 th , 2020	- Included Important notification of parachute drift in high wind operating environments
1.8	October 25 th , 2021	- IMU Calibration Instructions
2.0	April 14, 2022	- Revised Firmware Update Method for V3 Release - Added Status Indication for Sensor Error

2. Legends



Warning



Important



Tips



Reference

Using this Manual	2
1. Revision Notes	2
2. Legends	2
Disclaimer	5
Terms, Acronyms, & Abbreviations	6
Safety Instructions	7
Limitations	8
1. Operational & Environmental Conditions	8
Features, Specifications, Testing, & Compatibility	9
1. Features	9
2. Specifications	10
3. ASTM F3322-18 Compliance	11
4. Compatibility & Payloads	12
Warranty	15
What's in the Box	16
1. Parts Included	16
System Overview	17
1. Parachute Recovery System	17
2. Flight Termination System	18
3. Attachment Bracket	19
4. Manual Remote	20
Installation	21
1. Electronic Module	21
2. Parachute Pod	22
3. Safety Pin	23
4. Attachment Bracket – Side Bracket	24
5. Attachment Bracket – Top Plate	26
6. Flight Termination System	27
Battery & Charging	29
1. Battery Safety	29
2. Charging	29
3. Changing Electronic Module Battery	30
Firmware & SD Card	31
1. Firmware Updates	31
2. SD Card	32

Status Indications	33
1. PRS-M200 Indications	33
2. Remote Status Indication	34
3. Remote Synchronization	34
Operating Procedures	35
1. Hangar Checklist	35
2. Installation Checklist	35
3. Pre-Flight Checklist	35
4. In-Flight Checklist	36
5. Landing Checklist	36
6. Post-Flight Checklist (No Deployment)	36
7. Deployment Checklist	36
8. Post-Flight Checklist (With Deployment)	36
Maintenance & Care	37
1. Post-Flight (Monthly)	37
2. Transportation	37
3. Storage	37
4. Extended Storage Considerations	37
Frequently Asked Questions	38
Parachute Pod Deployment Procedures	39
Customer Support	40
Appendix A: Drone & Payload References	41
Appendix B: IMU Calibration Instructions	43

Disclaimer

- This parachute manual (pm) satisfies the requirements of ASTM F3322-18, Section 3.1.30.
 - This product has been designed for and should only be used by qualified professionals only.¹
 - This product is designed to increase the safety of both people and property on the ground during drone operations while potentially helping drone operators meet compliance requirements. However, this product is not a replacement for safe operating practices and should serve only as a last resort in the event of an emergency.
 - Before use, you shall refer to the drone manufacturers' documentation to determine if this product complies with specific operating requirements and warranty conditions of the drone. Failure to comply with the operating requirements of this product and/or drone manufacturer product may result in damage to the drone, damage to nearby property, harm to bystanders, and/or cause serious injury.
 - Always use proper judgment when attempting to mitigate risks and/or danger in emergencies. Do not make or attempt any alterations or adjustments to this product or its use as it could result in serious injury, or damage to the product or other property and it will void the warranty.
 - AVSS – Aerial Vehicle Safety Solutions Inc. (AVSS) assumes no liability and/or ownership of any failure event that may occur while the system is attached to a drone. The use of AVSS products is at the risk of the user.
 - This document and the information contained herein are proprietary and commercially confidential to AVSS. It is prohibited to use, disclose, reproduce, distribute, or use this user manual other than persons for which purchased the product.
-
-  THIS USER MANUAL MAY BE UPDATED AT ANY POINT AND WITHOUT NOTIFICATION. BEFORE USE, READ, IN ITS ENTIRETY, THE MOST RECENT VERSION OF THIS USER MANUAL TO UNDERSTAND ALL PROCEDURES, RISKS, AND RESTRICTIONS ASSOCIATED WITH THIS PRODUCT BEFORE OPERATING.

¹ Professional qualifications are determined by the jurisdiction/country in which the commercial drone is operating.

Terms, Acronyms, & Abbreviations

Terms & Definitions

AGL	Above ground level.
ASTM F3322-18	Standard describing the specifications for the design, testing, and manufacturing of drone parachute systems.
ATS	Automatic Triggering System that is independent of any flight critical system of the drone that will detect and initiate parachute deployment upon detection of a critical failure of the drone during flight.
Authorized Dealer	An AVSS approved distribution partner who sells the PRS-M200.
Drone	When referring to a drone, other relevant terms include Aircraft, RPAS, sUAS, UAS, and UAV.
End-User	The owner of the PRS-M200 who had purchased the system from an AVSS Authorized Dealer.
FTS	Flight Termination System is a device that will disable the propulsion system of the drone.
IP Rating	Ingress Protection Rating.
LiPo	Lithium-Polymer (Chemistry of battery).
Manual Remote	The manual triggering device that can initiate deployment of the parachute recovery system at the discretion of the remote pilot in command.
Minimum Operating Altitude	The lowest altitude at which the PRS-M200 is rated to deploy successfully as determined in the ASTM F3322-18 standard.
Parachute Pod™	This refers to the replaceable Parachute Pod™ that contains the parachute of the AVSS PRS-M200.
Position Mode	The PRS-M200 shall be used only in P-mode (Positioning): P-mode works best when the GPS signal is strong. The drone utilizes GPS and Forward and Downward Vision Systems to locate itself, automatically stabilize, and navigate between obstacles. Complete details can be found at www.DJI.com .
PRS	Parachute Recovery System.
Shall	“shall” versus “should” versus “may”, v—use of the word “shall” implies that a procedure or statement is mandatory and shall be followed to comply with this specification, “should” implies recommended, and “may” implies optional at the discretion of the supplier, manufacturer, or operator.

Safety Instructions





Recommendations

Eye Protection	As with any system designed to launch a mass at high velocity, precautions shall be taken to prevent potential injury.
Safety Pin Installation	The safety pin is designed as a failsafe to prevent injury from an unintentional ground deployment.
Never point the Parachute Pod™ towards anyone or anything	While the PRS-M200 includes features to prevent unintentional deployments, users shall be aware that the Parachute Pod™ is launched vertically. It is recommended that the operator maintains a clear area of at least 5 meters after the system has been powered.
Manual Trigger Disarming	Always disarm the system before approaching the drone after a landing or in the event of an aborted takeoff.
Ensure PRS-M200 is DISARMED before moving it	Do not pick up the PRS-M200 when it is armed because the sensors may interpret the movements as an in-flight failure.
Error Status	The system should not be used unless it is indicated that no errors are present. The system will not arm itself nor deploy in a failure scenario unless it has initialized successfully.
Low Battery	The PRS-M200 requires enough battery power to operate. Although the PRS-M200 can draw power from the drone as a backup if the battery becomes low during a flight, this feature is not to be used as a substitute for charging the battery before flight.
Parachute Pod™ Repacking	Only parachutes packed by AVSS are ASTM compliant. Parachute Pod™ shall be repacked or replaced annually only by AVSS. You will no longer be compliant and will void the warranty if you attempt or repack the Parachute Pod™.
Payload Configuration	Always follow DJI's maximum specified takeoff weight when adding payloads to the drone (See Compatibility & Payloads sub-section for a list of compatible payload configurations).
Position Mode	The auto-trigger system is designed to automatically detect abnormal flight behaviors. Flying in a controlled manner and avoiding erratic maneuvers ensures that the PRS-M200 can more accurately distinguish between pilot commands and loss of control. This is best accomplished by flying in Position Mode.
Rules and Regulations	Pilots shall follow the rules and regulations put in place by civil aviation or government bodies in their operating regions.

Limitations

1. Operational & Environmental Conditions

1. DJI M200 Flight Mode = Position Mode
2. Maximum Take Off Weight = 6.60kg²
3. Minimum Operating Altitude = 34.9 m (114.5 ft)
4. Manual Remote Range = >2km (>1.2mi)
5. Temperature Range = -20°C to +50°C (-4°F to 122°F)

	ONLY FLY THE PRS-M200 IN POSITION MODE.
	IF THE PARACHUTE IS DEPLOYED IN HIGH WINDS, THE PARACHUTE CAN DRIFT. THE PILOT MUST CONSIDER DRIFT ZONES AND THE CONSEQUENCES IN THEIR RISK ASSESSMENT.
	THE DJI M200 SERIES IS RATED BY DJI FOR A MAXTOW OF 6.14KG. BASED ON AVSS FLIGHT TESTING, THE DJI M200 SERIES WITH THE PRS-M200 CAN FLY AT A MAXTOW OF 6.60KG. BEFORE EXCEEDING THE DJI LISTED MAXTOW, PLEASE REFER TO YOUR SPECIFIC CIVIL AVIATION AUTHORITY REGULATIONS.
	LEAVING THE PRS-M200 ON FOR A PROLONGED PERIOD BEFORE TAKING OFF CAN CAUSE IT TO ARM IF ENVIRONMENTAL CONDITIONS ARE CHANGING (E.G., TEMPERATURE DRIFT).
	IF THE PRS-M200 IS INVOLVED IN A MAJOR CRASH, DO NOT REUSE THE PRS-M200 WITHOUT CONTACTING AVSS'S CUSTOMER SUPPORT AND SPEAKING WITH A REPRESENTATIVE BEFORE THE NEXT FLIGHT.

² If using the DJI M200 series above 6.14kg:

- It is recommended to fly at a reduced speed to avoid overshooting corners
- It is recommended to avoid flying in wind conditions that reach the upper limits of the specification
- It is recommended to increase maintenance and inspection frequency
- When taking off with a front-heavy payload, you should be aware that the M200 may tilt forwards as the propellers spin up before the flight controller realizes the Centre of Gravity is off and the motors will shutoff

Features, Specifications, Testing, & Compatibility

The ASTM F3322 compliant PRS-M200 has been designed to easily integrate with DJI Matrice 200 series drones. The attachment bracket secures the PRS-M200 without interfering with onboard sensors and can be quickly and easily removed for transport. The system includes an electronic module to power the Parachute Pod™ and flight termination system. The onboard system comes equipped with an automatic triggering system to deploy the parachute. An independent remote for manually deploying the parachute gives you constant control over your operations.

1. Features

ASTM F3322-18 Compliance	The system satisfies ASTM F3322-18.
Attachment Bracket	The custom mounting bracket allows the PRS-M200 to be quickly installed for use in the field. The side components of the bracket are designed to remain on the drone and fit inside the original DJI M200 series carrying case when not in use.
Independent Power Source	The PRS-M200 is equipped with an independent power source that allows the system to deploy if the drone loses power.
Safety Pin	A removable safety pin as a mechanical method to reduce the consequences of deployment while transporting the system.
Spring-Based Ejection	A high-energy spring is used to eject the parachute. This non-pyrotechnic system is safe for travel on commercial airlines.
Automatic Trigger System	The Auto Trigger System (ATS) automatically detects failures and triggers the parachute release.
Manual Remote	An independent manual deployment remote allows the pilot to instigate a parachute deployment.
Flight Termination System	Plug-and-play system that cuts power to the motors in the event of a failure and to ensure that the parachute does not become entangled in the drone's propellers.
Audible Buzzer	An audible buzzer on the drone will attempt to notify bystanders that the PRS-M200 has deployed and the DJI M200 series is descending.
Low Descent Rate	The parachute is designed to greatly reduce the descent velocity of the drone in the event of a failure.
Flight Data Logging	Flight data logging to a dedicated micro SD Card.
Parachute Pods™	Easily replaceable Parachute Pod™.

2. Specifications

OVERVIEW³

Total Weight	790 grams (1.74 lbs)
Average Descent Rate	4.01 m/s (13.15 fps)
Average Descent Rate (MinTOW)	3.90 m/s (12.8 fps)
Average Descent Rate (DJI MaxTOW)	4.16 m/s (13.65 fps)
Average Descent Rate (AVSS MaxTOW) ⁴	4.31 m/s (14.14 fps)
Average Impact Energy	45.99 Joules (33.92 ft-lb)
Average Impact Energy (MinTOW)	38.51 Joules (28.40 ft-lb)
Average Impact Energy (DJI MaxTOW)	53.47 Joules (39.44 ft-lb)
Average Impact Energy (AVSS MaxTOW) ⁵	61.30 Joules (45.21 ft-lb)
Parachute Reuse Method	Prepacked Pods
Deployment Technology	Spring
Deployment Trigger	Manual and/or Autonomous

PARACHUTE RECOVERY SYSTEM

Main System Weight	469 grams (1.04 lbs)
Deployment Release Time	20 ms
Time to Inflation	0.57s to 1.30s
Battery Life	6 hours
Operating Temperature	-20°C to +50°C (-4°F to 122°F)

PARACHUTE POD™

Parachute Size	3m ²
Risers/Attachment Location	Internal

FLIGHT TERMINATION SYSTEM

FTS Method	Electrical Connectors
Integration Process	Securely Slide into Battery Compartment

ATTACHMENT BRACKET

Material	Carbon Fibre
Attachment Location	Top Mounted

INDEPENDENT MANUAL REMOTE

Range	>2 KM (>1.24 mi)
Frequency	915MHz (NA) / 868MHz (EU)

³ Subject to change without warning based on supply chain material availability, payload selection, ongoing testing results, and environmental conditions.

⁴ Based on additional testing completed in October 2020

⁵ Based on additional testing completed in October 2020

3. ASTM F3322-18 Compliance

The PRS-M200 has met the compliance requirements for ASTM F3322-18; the standard specification for commercial sub-25kg drones (small unmanned drone system (sUAS)) parachute. As per ASTM International (2018):

“Scope: 1.1 This specification covers the design and manufacture requirements for deployable parachutes of small unmanned drone (sUA). This specification defines the design, fabrication, and test requirements of installable, deployable parachute recovery systems (PRS) that are designed to be integrated into a sUA to lessen the impact energy of the system should the sUA fail to sustain normal stable safe flight. Compliance with this specification is intended to support an applicant in obtaining permission from a civil aviation authority (CAA) to fly a sUA over people.

1.2 This specification is applicable to the design, construction, and test of deployable parachute recovery systems that may be incorporated into the system or structure, or both, of sUA seeking civil aviation authority (CAA) approval in the form of technical standard orders (TSO), flight certificates, flight waivers, flight permits, or other like documentation.

1.3 Units—The values stated in inch-pound units are to be regarded as the standard. The values given in parentheses are mathematical conversions to SI units that are provided for information only and are not considered standard.

1.4 This standard does not purport to address all of the safety concerns, if any, associated with its use. It is the responsibility of the user of this standard to establish appropriate safety, health, and environmental practices and determine the applicability of regulatory limitations prior to use.

1.5 This international standard was developed in accordance with internationally recognized principles on standardization established in the Decision on Principles for the Development of International Standards, Guides and Recommendations issued by the World Trade Organization Technical Barriers to Trade (TBT) Committee.”⁶

⁶ DOI: 10.1520/F3322-18.

4. Compatibility & Payloads

Compatibility

The PRS-M200 is compatible with all DJI M200 series (M200 V1, M200 V2, M210 V1, M210 V2, M210 RTK V1, M210 RTK V2).

When integrating the PRS-M200 to the M210 RTK (V1 & V2), it may require attaching the provided spacers to ensure the D-RTK antennas are fully unfolded and securely locked.



WHEN INTEGRATING THE PRS-M200 TO THE M210 RTK (V1 & V2), IT MAY REQUIRE ATTACHING THE PROVIDED SPACERS TO ENSURE THE D-RTK ANTENNAS ARE FULLY UNFOLDED AND SECURELY LOCKED.

Payload Weight Availability

The PRS-M200 is designed for a Maximum Take-Off Weight of 6.60kg. When attaching any payload and/or attachment to the DJI Matrice 200 series, ensure that the total weight does not exceed 6.60kg.

M200 + PRS-M200 (KG)						
DJI M200 Series	Battery	Drone + Battery Weight	PRS-M200 Weight	Total Weight	Available Capacity (6.14kg)	Available Capacity (6.60kg)
DJI M200 V1	TB50	3.80	0.79	4.59	1.55	2.01
	TB55	4.53	0.79	5.32	0.82	1.28
DJI M210 V1	TB50	3.84	0.79	4.63	1.51	1.97
	TB55	4.57	0.79	5.36	0.78	1.24
DJI M210 RTK V1	TB50	4.27	0.79	5.06	1.08	1.54
	TB55	5.00	0.79	5.79	0.35	0.81
DJI M200 V2	TB55	4.69	0.79	5.48	0.66	1.12
DJI M210 V2	TB55	4.80	0.79	5.59	0.55	1.01
DJI M210 RTK V2	TB55	4.91	0.79	5.70	0.44	0.90

Payload Configuration Charts

As of 2020-05-07, the following payload combinations, if using the user manual data located on DJI’s and payload partners’ website⁷, are within the 6.60kg Maximum Take-Off Weight criteria. Be aware, due to the potential unannounced changes by the supporting drone and payload manufacturers, these charts are subject to change without any notification. The user is solely responsible for verifying the weight accuracies and calculating the weight of additional items attached to the drone.

Single Payload Configuration Chart

Single Payload (KG)												
DJI M200 Series	Battery	SR 4P	SA AGx710	U10 Methane	WL Z15	X4S	X5S	X7 (182g)	XT	XT2 (25mm)	XT2 (other)	Z30
		0.350	0.270	0.534	0.500	0.253	0.461	0.631	0.270	0.629	0.588	0.556
DJI M200 V1	TB50	4.94	4.86	5.12	5.09	4.84	5.05	5.22	4.86	5.22	5.18	5.15
	TB55	5.67	5.59	5.85	5.82	5.57	5.78	5.95	5.59	5.95	5.91	5.88
DJI M210 V1	TB50	4.98	4.90	5.16	5.13	4.88	5.09	5.26	4.90	5.26	5.22	5.19
	TB55	5.71	5.63	5.89	5.86	5.61	5.82	5.99	5.63	5.99	5.95	5.92
DJI M210 RTK V1	TB50	5.41	5.33	5.59	5.56	5.31	5.52	5.69	5.33	5.69	5.65	5.62
	TB55	6.14	6.06	6.32	6.29	6.04	6.25	6.42	6.06	6.42	6.38	6.35
DJI M200 V2	TB55	5.83	5.75	6.01	5.98	5.73	5.94	6.11	5.75	6.11	6.07	6.04
DJI M210 V2	TB55	5.94	5.86	6.12	6.09	5.84	6.05	6.22	5.86	6.22	6.18	6.15
DJI M210 RTK V2	TB55	6.05	5.97	6.23	6.20	5.95	6.16	6.33	5.97	6.33	6.29	6.26

⁷ Please refer to [Appendix A: Drone & Payload References](#) for the complete list of references.

Dual Payload Configuration Chart

Dual Payload (KG)								
DJI M200 Series	Battery	U10 + X5S	U10 + XT2 (25mm)	U10 + Z30	WL Z15 + XT2 (25mm)	WL Z15 + Z30	Z30 + X5S	Z30 + XT2 (25mm)
		0.995	1.163	1.090	1.129	1.056	1.017	1.185
DJI M200 V1	TB50	5.59	5.75	5.68	5.72	5.65	5.61	5.78
	TB55	6.32	6.48	6.41	6.45	6.38	6.34	6.51
DJI M210 V1	TB50	5.63	5.79	5.72	5.76	5.69	5.65	5.82
	TB55	6.36	6.52	6.45	6.49	6.42	6.38	6.55
DJI M210 RTK V1	TB50	6.06	6.22	6.15	6.19	6.12	6.08	6.25
	TB55	6.79	6.95	6.88	6.92	6.85	6.81	6.98
DJI M200 V2	TB55	6.48	6.64	6.57	6.61	6.54	6.50	6.67
DJI M210 V2	TB55	6.59	6.75	6.68	6.72	6.65	6.61	6.78
DJI M210 RTK V2	TB55	6.70	6.86	6.79	6.83	6.76	6.72	6.89

Warranty

- AVSS warrants that the PRS-M200 and its accessories are free from defects and fit for the operational purpose intended.
- The warranty period for the PRS-M200 is, the earliest of, twelve (12) months after purchase, or after three Parachute Pod™ deployments, which starts on the date listed as per the user's invoice from an Authorized Dealer.
- This warranty requires the PRS-M200 to be shipped to AVSS's location for analysis and may either be fixed, replaced and/or deemed voided of warranty at the sole discretion of AVSS.
- If the customer believes the PRS-M200 did not properly function or deployed the Parachute Pod™ in a non-failure event (False Positive), the customer must send AVSS the following files:
 - PRS-M200 Data
 - DJI M200 Series DAT data
 - DJI M200 Series Text File
- If the PRS-M200 is deemed void, the cost of analysis and shipping shall be the responsibility of the end-user. Nothing herein contained shall be construed to exclude or limit any warranty, express or implied by law.
- AVSS hereby declares that the warranty shall be deemed void if the PRS-M200 is not used for the intended operational uses and/or if alterations, tampering, or any actions deemed comprising by AVSS, directly or indirectly, of the PRS-M200 This includes, but not limited to, non-standard use, the use of potentially disabling anti-operations technology, and/or unintended damage by the end-user.
- The manual remote for the parachute is warrantied against any manufacturing default.
- The product warranty does not cover water damage.
- If the product is used or handled in any way otherwise described within this user manual, the warranty shall be void.
- The PRS-M200 purpose is to assist in decreasing the ground impact energy caused by the DJI M200 series mid-flight failure. The end-user cannot in any circumstances from AVSS pursue any compensation or allowance if their drone is damaged.
- It is the responsibility of the purchaser to contact AVSS to obtain additional or updated copies of the user manual.

What's in the Box

1. Parts Included

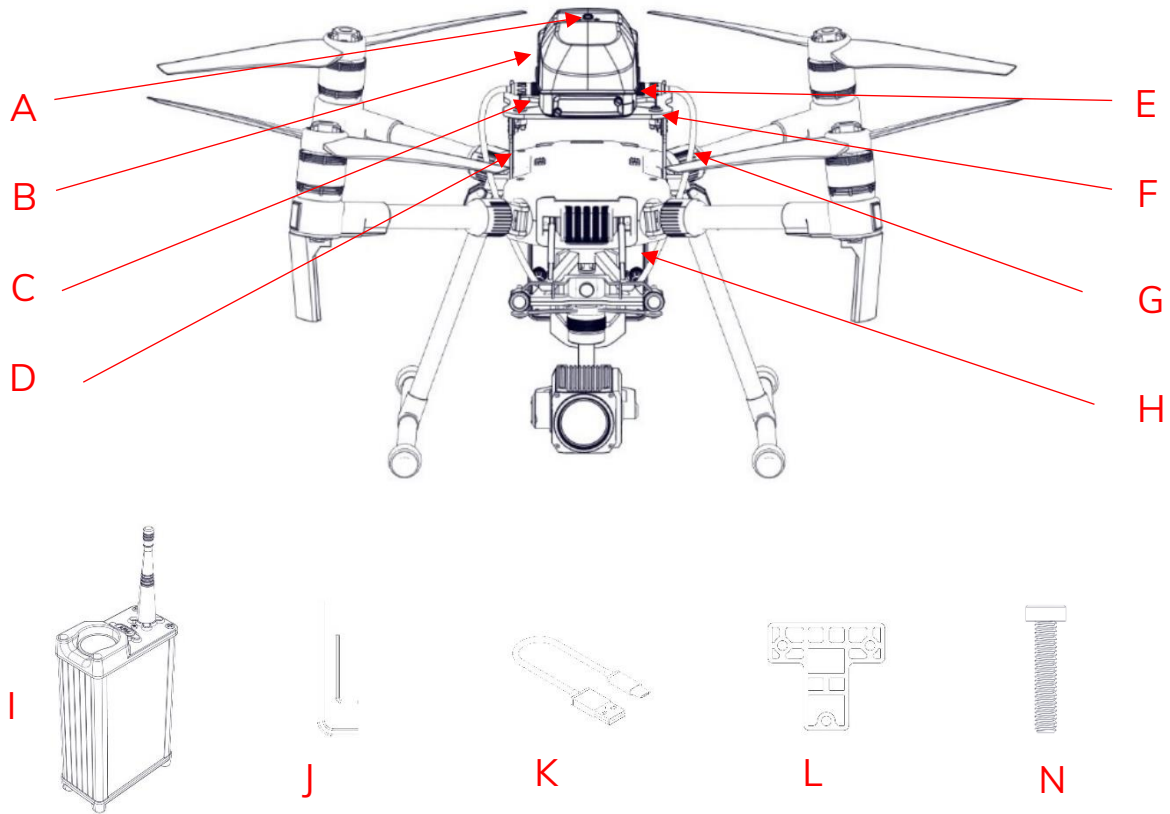

A. Safety Pin Location

B. Parachute Pod™

C. FTS Connectors (2)

D. Side Brackets (2)

E. Electronic Module

F. Top Plate

G. FTS Cables (2)

H. FTS (2)

I. Manual Remote with Battery

J. Allen Keys (2)

K. USB-C to USB-A Cable

L. M210 RTK Spacers (2)

M. Installation Hardware (6)

System Overview

1. Parachute Recovery System

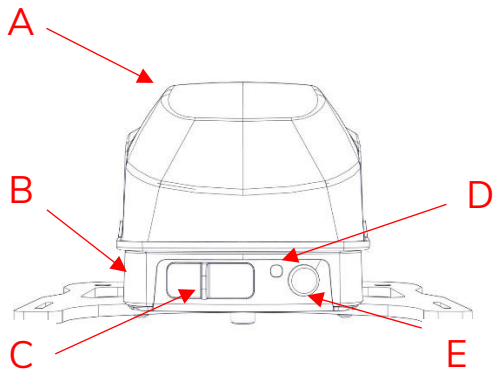

- A. Parachute Pod™
- B. Electronic Module
- C. USB/micro SD Card Slot
- D. Status LED
- E. Power Button

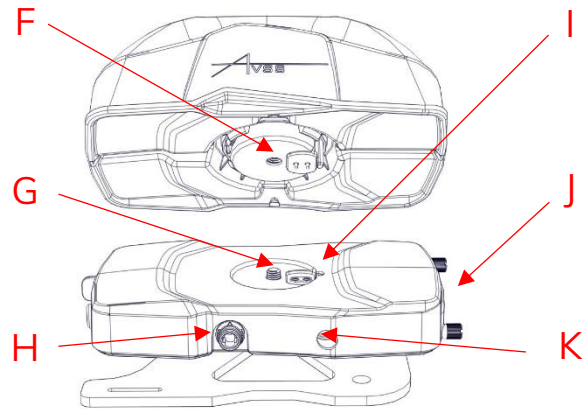

- F. Firing Pin Receptacles
- G. Orientation Key
- H. FTS Connector (both sides)
- I. Electrical Contacts
- J. Battery Door
- K. Pin Status LED

2. Flight Termination System

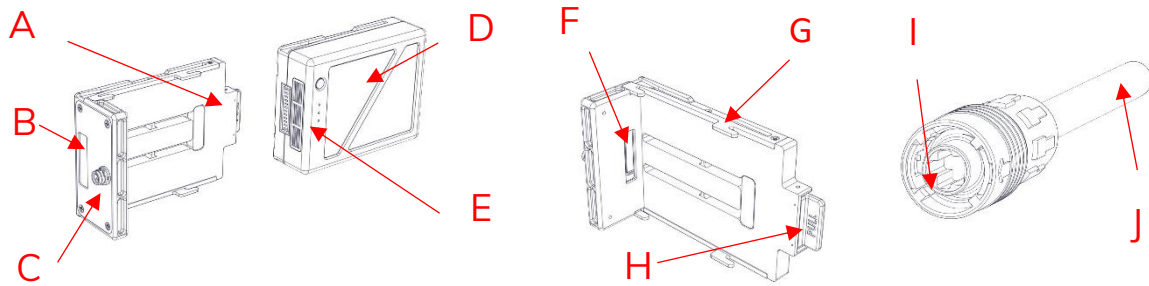

A. FTS Release

B. FTS Female Connector

C. FTS to Electronic Module Connector

D. TB50/TB55 Battery

E. TB50/TB55 Female Connector

F. FTS Male Connector

G. FTS to M200 Sliding Rails

H. FTS to Electronic Module Connector

I. FTS to Electronic Module Connector

J. FTS Cable to FTS Connector

3. Attachment Bracket

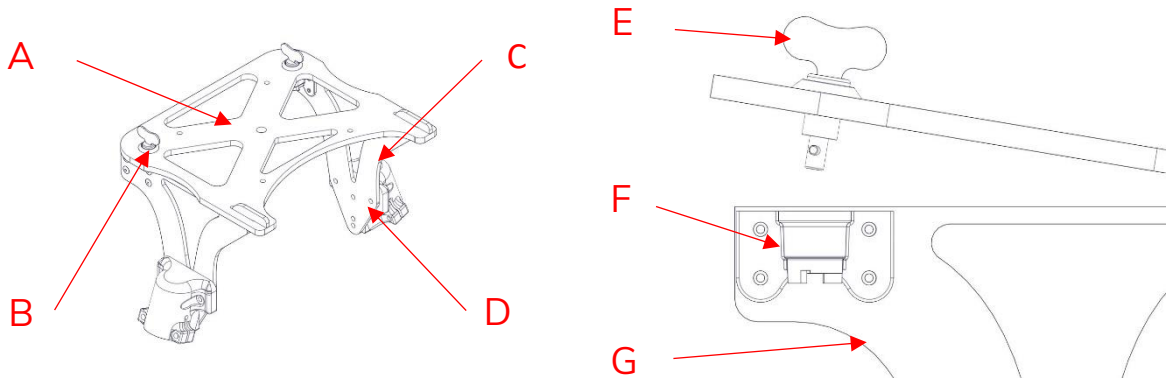

- A. Top Plate
- B. Quarter Turns
- C. Side Plates
- D. DJI M200 Screw Holes

- E. Quarter Turn Tab
- F. Quarter Turn Receptacles
- G. Side Plate

4. Manual Remote

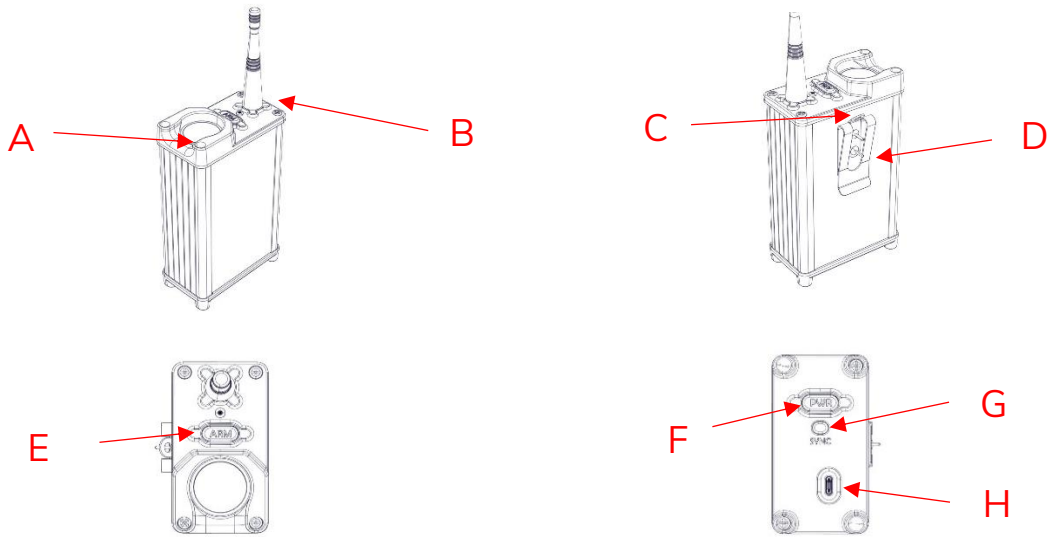



- A. Deployment Button
- B. Antenna
- C. Lanyard Attachment
- D. Belt Clip

- E. Arm Button
- F. Power Button
- G. Sync Button
- H. USB-C Charging Port

Installation

⚠ ENSURE THE BOTH THE PRS-M200 AND DRONE ARE OFF DURING INSTALLATION UNLESS REQUIRED FOR COMPLETING THE STEP.

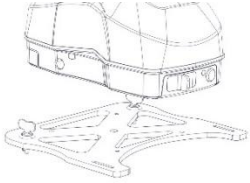
1. Electronic Module



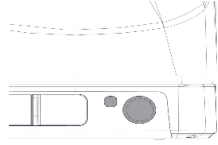



Attaching the Parachute Pod™ and Electronic Module to the Attachment Bracket's Top Plate			
Step 1	Orient Bracket	Place the attached Parachute Pod™ and Electronic Module on above the top plate as shown. Ensure that the On/Off button is facing away from the quarter turns as shown.	
Step 2	Align Screw Holes	Place the PRS-M200 against the plate and ensure that the screw holes are aligned.	
Step 3	Insert Screws	Use the 4 Phillips head screws provided to connect the PRS-M200 to the top plate.	

Turning on the PRS-M200			
Step 1	Turn on System	To turn on PRS-M200, press on the ON/OFF switch.	

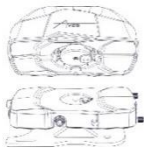
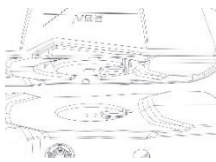
2. Parachute Pod

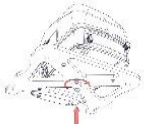

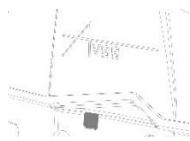
- ONLY REMOVE THE PARACHUTE POD IF THE PARACHUTE HAS BEEN DEPLOYED
- ENSURE THAT THE PRS-M200 IS OFF BEFORE REPLACING THE POD

Attaching and changing the Parachute Pod™			
Step 1	Remove Parachute Pod™ from PRS-M200	Using the supplied hex key, unscrew the M6 bolt until the pod can be removed. Do not reuse the bolt and washer when attaching a new Parachute Pod™	
Step 2	Align New Parachute Pod™	Remove the new parachute pod from its shrink wrap packaging. Align the Parachute Pod™ above the electronics module such that the electrical contacts will mate properly (as shown).	
Step 3	Press Parachute Pod™ Against Module	Press the Parachute Pod™ against the electronics module. The two shall mesh together so that they do not slide against each other.	
Step 4	Slide Washer onto M6 Bolt	Take a new M6 bolt and slide on a new washer. The washer is slightly cone shaped. Ensure that the narrow end is towards the head of the bolt.	
Step 5	Tighten Bolt	Using the M5 hex key, tighten the bolt.	
Step 6	Power On	Place the PRS-M200 on a flat surface and turn on.	
Step 7	Check Continuity	Check that the continuity light on the side of the PRS-M200 is lit. This indicates that the electrical contacts are properly connected to the pod.	
Step 8	Power Off	Power off the module. The new Parachute Pod™ is now successfully installed.	

3. Safety Pin

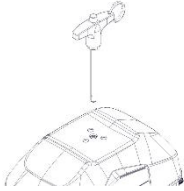
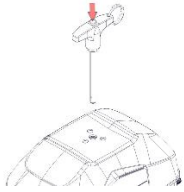
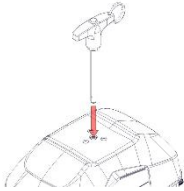
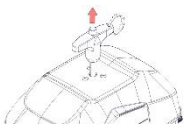
Inserting and Removing the Safety Pin			
Step 1	Align Safety Pin	Align the safety pin with a top hole located on the Parachute Pod™.	
Step 2	Press Button	To insert safety pin, press and hold the button on the top of the T-handle.	
Step 3	Insert Safety	Slide the pin into the slot.	
Step 4	Release Button	Once fully inserted, release the Pin button.	



⚠ THE SAFETY PIN SHALL BE REMOVED BY THE OPERATOR BEFORE THE DRONE TAKESOFF.

4. Attachment Bracket – Side Bracket

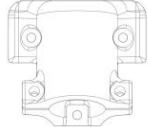
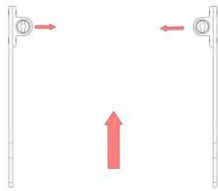
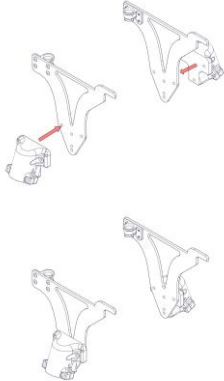
! IF THE DRONE IS EQUIPPED WITH RTK ANTENNAS, THE PROVIDED SPACERS SHALL BE USED.

Side Brackets for the DJI M200 V1, DJI M200 V2, DJI M210 V1, & DJI M210 V2			
Step 1	Unscrew DJI M200 Landing Gear	Remove the 3 x M3 screws from each of the landing gear brackets using the provided hex key	
Step 2	Attach AVSS Side Bracket	Place the carbon-fiber bracket side plates as shown. The metal quarter-turn receptacles should be facing inwards and should be positioned towards the front of the drone.	
Step 3	Screw DJI M200 Landing Gear	Screw in the side plates and the DJI landing gear brackets using the provided long M3 screws. (The original screws are too short to use with the PRS-M200 bracket!)	

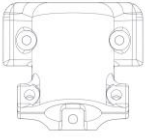
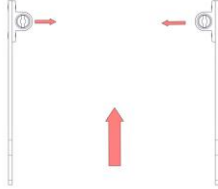
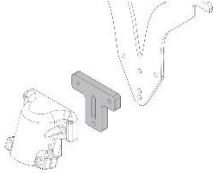
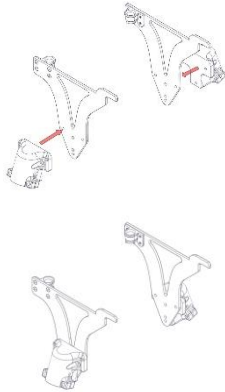

! THE BRACKET SYSTEM SHALL BE FIRMLY ATTACHED. WHEN THE PARACHUTE DEPLOYS, THE PARACHUTE WILL TRANSFER THE ENTIRE WEIGHT OF THE DRONE TO THE ATTACHMENT BRACKET.

Side Brackets for the DJI M210 RTK V1, & DJI M210 RTK V2			
Step 1	Unscrew DJI M200 Landing Gear	Remove the 3 x M3 screws from each of the landing gear brackets using the provided hex key	
Step 2	Attach AVSS Side Bracket	Place the carbon-fiber bracket side plates as shown. The metal quarter-turn receptacles should be facing inwards and be positioned towards the front of the drone.	
Step 3	Attach Spacers to Bracket	Add the provided spacer next. The carbon fiber side plate should be closest to the drone	
Step 4	Screw DJI M200 Landing Gear	Use the 14mm screws to attach the DJI landing gear bracket, spacer, and carbon fiber side plate.	
Step 5	Verify that Side Plates are Secured	The bracket should not wiggle or rotate. If it does, tighten the screws.	

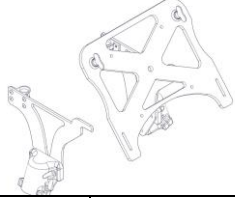
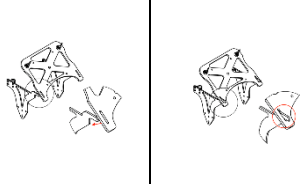

THE SIDE BRACKETS ONLY NEED TO BE INSTALLED ONCE AND CAN BE LEFT ON THE DRONE WHEN IT IS STORED OR WHEN THE PRS-M200 IS NOT IN USE. BEFORE EACH FLIGHT, YOU SHALL VERIFY THAT THE BRACKET IS STILL PROPERLY SECURED TO THE DRONE

5. Attachment Bracket – Top Plate

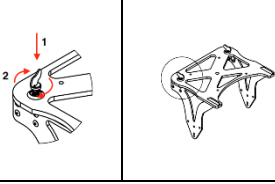
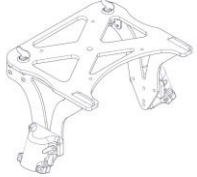
Securely Attaching the Bracket Top Plate			
Step 1	Align Top Plate	Align the top plate with the side plates. The quarter turns should be towards the front of the drone.	
Step 2	Slide Top Plate	Slide the Top Plate to the back of the Side Brackets by meshing the cut-outs on the top plate with the side plate hooks so that they protrude as shown.	
Step 3	Rotate Plate	Rotate the top plate so that it lies flat on top of the side plate while ensuring that the quarter turns to fall into the receptacles.	
Step 4	Rotate Quarter Turns	Hold the quarter turns at the angle shown and push until they bottom out. Rotate clockwise until they lock into place. An audible click should be heard and felt.	
Step 5	Verify that Top Plate is Secured	Test that the quarter turns are fastened securely. Pull the top bracket plate up. The plate should rise slightly and then be stopped by the quarter turns.	

6. Flight Termination System

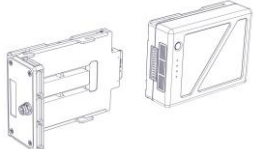
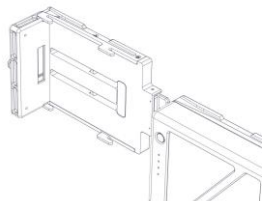
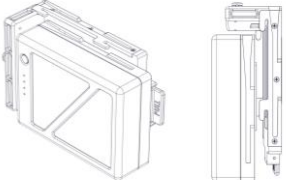
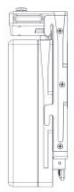
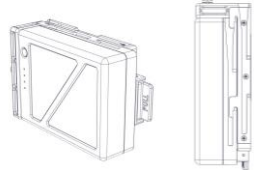
Inserting the TB50 or TB55 Battery into FTS module			
Step 1	Orienting the Battery	Orient the battery connector so that it is facing the FTS module.	
Step 2	Warning	Do not slide the battery into the FTS module.	
Step 3	Sliding Battery	Line up the battery grooves of the battery with the rails of the FTS module.	
Step 4	Push Battery Against Module	Push battery against the FTS module ensuring that the rails fall into the grooves. The face of the battery should be flat against the FTS enclosure.	
Step 5	Slide Battery to Connect	Slide the battery forward. Ensure that the connector snaps into place with an audible click.	

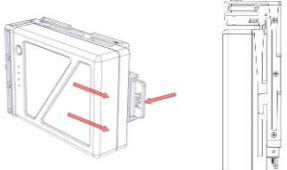
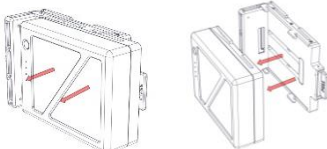
Disconnecting the TB50 or TB55 Battery from the FTS module			
Step 1	Pull the battery release	To disconnect the battery, pull on the release lever and slide the battery a small distance backward. It will move slightly and then stop. Do not try to force the battery to slide out!	
Step 2	Pull the Battery Away	Pull the battery away from the FTS module as shown	



- MAKE SURE ALL CONNECTORS ARE PROPERLY ATTACHED TO THE FLIGHT TERMINATION SYSTEM AND PRS-M200.
- ALWAYS ALIGN THE GROOVES ON THE DJI INTELLIGENT FLIGHT BATTERY WITH THE FLIGHT TERMINATION SYSTEM SLOT TRACKS.
- TO DETACH FLIGHT TERMINATION SYSTEM, PRESS THE DJI M200 BATTERY REMOVAL BUTTON.
- DO NOT LEAVE METAL TERMINALS EXPOSED TO OPEN AIR WHEN NOT IN USE.

Battery & Charging

1. Battery Safety

- The PRS-M200 is equipped with A 1S LiPO battery.
- The PRS-M200 shall be charged before use and only by an AVSS supplied or approved USB-C Cable.
- Failure to comply may result in damage to the battery, the PRS-M200, severe overheating, and/or fire.
- Do not store the PRS-M200 and/or any of the associated parts and accessories in any extreme cold, hot or humid environments.
 - Less than 3 months: -20° to +45° C
 - More than 3 months: +22° to +28° C
- If left in unsuitable environments, the system and/or components may be damaged, the warranty will shall be void, and the items may not properly function.
- During charging, keep watch on the charging process and react to any potential problems that may occur.
- Never leave unprotected charging batteries unattended.







DO NOT TAKE OFF WHEN THE BATTERY INDICATOR IS RED.

2. Charging

Battery Indications

- The battery charge status on both devices can be checked by pressing the synchronization (“Sync”) button after the startup sequence is finished. The battery colors are the following:

LED Color	 (red)	 (yellow)	 (green)	 (white)
Battery %	0-25	25-50	50-75	75-100





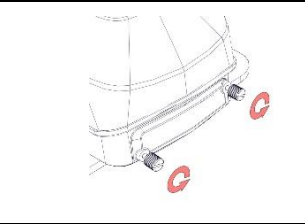
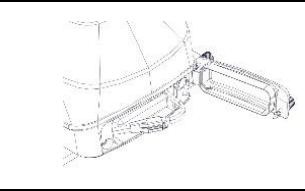
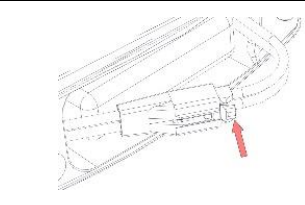
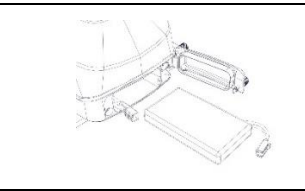
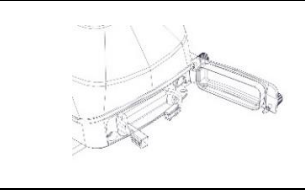
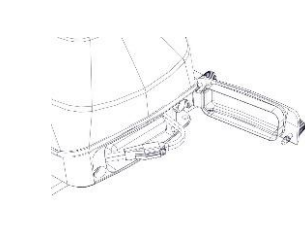
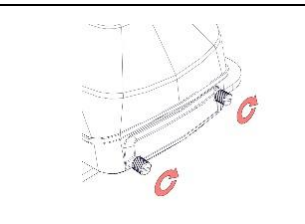

THE PRS-M200 HAS BUILT-IN CHARGING CIRCUIT TO MAINTAIN AN ADEQUATE LEVEL OF POWER, WHICH WILL GATHER POWER FROM THE DJI M200 BATTERIES THROUGH THE FLIGHT TERMINATION SYSTEM WHEN THE PRS-M200 BATTERY LEVEL IS LESS THAN 20%.

3. Changing Electronic Module Battery

Replacing PRS-M200 Battery			
Step 1	Turn the Battery Knobs	Using the knob, turn the knobs to open the battery compartment door.	
Step 2	Open Battery Door	Using the knob, turn and open the battery compartment door.	
Step 3	Disconnect battery connector	Press the release on the battery connector and unplug the cable.	
Step 4	Remove Battery	Slowly remove battery from storage compartment.	
Step 5	Orient Battery and Cable	Orient the new battery so that the cable is as shown in the corner.	
Step 6	Plug-in Battery	Plug-in the battery connector to the cable inside the battery compartment of the electronic module. Proper attachment will result in a “click” sound and will be latched.	
Step 7	Close Battery Door	Once the battery and cable are neatly packed into the compartment, close the battery door and tighten knob. Ensure that the cable is not being pinched by the door.	

Firmware & SD Card

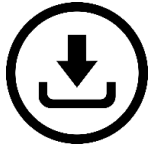
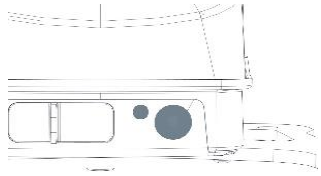
1. Firmware Updates

Updating the Firmware			
Step 1	Download firmware	Download the firmware from the bottom of the page on https://www.avss.co/products/prs-for-dji-m200/	
Step 2	Copy the firmware on a SD card	Copy the firmware on a SD card and insert in the PRS-M200. Do not change the file names of the Firmware.	
Step 3	Remove archive attribute of the file	The PRS-M200 skips over the archived files to avoid reinstalling the same firmware. In the “File Properties”, remove the “Archive Attributes”.	
Step 4	Firmware LED	White LED indicates that the firmware is being downloaded and, then, will restart. If there is an issue, the LED will go Red.	
Step 5	Turn on the PRS-M200	The firmware will be updated automatically on start-up. The LED will be yellow when complete.	
Step 6	Turn on the remote	Keep the remote at least 2 meters from the PRS-M200. The remote firmware will be updated on the first communication. The LED will be green when the firmware update is complete.	

 LED TURNS OFF WHILE INSTALLING THE NEW FIRMWARE. DO NOT POWER OFF THE MODULE UNTIL THE LED INDICATOR COMES BACK ON.

2. SD Card

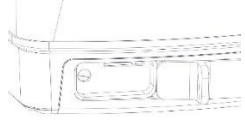
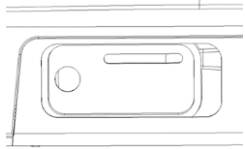
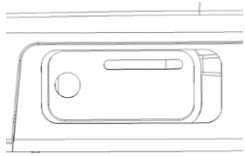
Removing and/or Inserting the SD Card			
Step 1	Open Door	Pull the tab on the charging port cover to open it.	
Step 2	Remove SD card	Gently press the SD card in to release the latch and then pull the card out of the slot. Use Tweezers if necessary.	
Step 3	Insert SD Card	To insert the SD card, slide it into the slot with the metal contacts facing up. An audible click should be heard when it connects properly.	

Status Indications

The PRS-M200 status, sometimes referenced as “Heartbeat” is indicated using a combination of LED color and buzzer signals. The PRS-M200 Status LED is located next to the ON/OFF switch. The LED color on PRS-M200 and remote indicates the stage of the flight. The remote LED indicates its state for 2 seconds and blinks the color of the PRS-M200 when a connection is established. The buzzers indicate secondary information which can be either continuous and require action or show a single event for user information.

1. PRS-M200 Indications

#	Status	LED ⁸ / Buzzer ⁹	Required action
1	Power on		
2	Synchronization		Hold Sync and turn on the remote
3	Updating firmware		See firmware section
4	Initializing		
5	FTS not connected		Connect the FTS cable to pass initialization ¹⁰
6	FTS diagnostic failed		Change FTS module or FTS cable
7	Initialized		
8	POD not found		Install/replace the pod
9	Very low battery (~1 hour ¹¹)		Replace/charge the battery
10	SD error		Ensure SD card is readable and properly inserted
11	Searching for RF		Turn on the remote (make sure it is bound to the PRS-M200)
12	Standby		SD card Error, ready to take off
13	Standby		Ready to take off (No error)
14	ATS Armed		ATS is active, SD error
15	ATS Armed		ATS active (No error)
16	FTS activated		Immediate deployment, keep away

⁸ Purple, Blue, Yellow, Red, Cyan, Green, Off

⁹ Buzzer is illustrated by lines around the color marks

¹⁰ Disconnection of the FTS after the initialization produces the same error and needs a power cycle to run diagnostic again

¹¹ Dependent on environmental factors and number of battery charge cycles

17	Sensor Error		Check Event log on the SD card. IMU calibration may be required.
----	--------------	--	--

2. Remote Status Indication

The LED on the remote indicates its status for 2 seconds and blinks the status of the PRS-M200 so the pilot can monitor the status of the PRS-M200 in the sky conveniently.



The remote status has the following colors:

Searching	Y
Standby	G
Armed	C
Critical/Triggered	R

3. Remote Synchronization

1. Make sure that both devices are off.
2. Hold the Sync button on the remote and, while turning it on, until the LED turns white.
3. To increase the channel, press and hold the arm button until the LED turns off then release. Repeat to increase the channel further. Number of channels depends on the local regulations.
4. Hold the Sync button on the PRS-M200 and while turning it on. The LED should be white.
5. Hold the Sync button on the remote and turn it on.
6. Both devices will generate a tone and Sync.

⊘ ONCE A DEVICE IS PUT TO SYNC MODE IT WILL SYNCHRONIZE WITH THE FIRST DEVICE IT FINDS. TO PREVENT UNINTENDED SYNCHRONIZATION, SYNCHRONIZE ONLY A SINGLE PRS-M200 AND A SINGLE REMOTE AT THE SAME TIME.

Operating Procedures

1. Hangar Checklist

- Make sure battery is fully charged
- Make sure that the memory card is inserted and has enough storage space

2. Installation Checklist

- Ensure that the PRS-M200 and bracket are not damaged
- Ensure that the PRS-M200 top plate and main system are securely attach
- Attach side brackets to the drone
- Attach top plate to side brackets
- Verify that bracket quarter turns are connected securely
- Check that the FTS connectors on the electronics module, FTS module and cable are clean and undamaged
- Insert the batteries and FTS modules into the drone, ensuring they are secure (audible click)
- Plugin FTS cables to FTS modules (audible click)
- Passing under the landing gear leg, plug the FTS cable into the electronics module
- Ensure that both FTS cables are securely connected and cannot interfere with propellers
- Check that manual remote antenna is oriented vertically

3. Pre-Flight Checklist

- Perform M200 Preflight checks
- Ensure drone is in position mode
- Connect FTS cables with PRS-M200 electronic module
- Turn on PRS-M200 Remote
- Turn on PRS-M200 by turning on the DJI M200 series
- Check continuity
- Check FTS status LED
- Check the buzzers and lights (heartbeat)
- Check battery level
- Wait for successful initialization
- Ensure no errors are present
- Remove safety pin
- Move at least 5 meters away from the drone
- Arm manual remote
- Arm drone
- Takeoff and climb to minimum deployment altitude



AUTO-TRIGGER WILL ONLY ARM ONCE AN ALTITUDE OF 35M IS REACHED.

4. In-Flight Checklist

- Always fly in Position Mode
- Fly in a safe and controlled manner
- Avoid flying over people if unnecessary

5. Landing Checklist

- Land drone gently on a level surface a safe distance from people
- Disarm the drone once it has landed
- Disarm manual remote trigger
- Do not approach drone until the ATS is disarmed

6. Post-Flight Checklist (No Deployment)

- Ensure PRS-M200 is disarmed before approaching drone
- DO NOT STAND DIRECTLY OVER THE PRS-M200 WHEN APPROACHING THE DRONE
- Turn off PRS-M200 BEFORE handling the drone
- Insert the safety pin
- Turn off drone
- Disconnect FTS cable before removing batteries
- Inspect PRS-M200 for damage
- Check battery level

7. Deployment Checklist

- If necessary, the system can be deployed manually using the remote trigger
- If possible, fly over a safe area free of people, cars or obstacles
- Press and hold the trigger button on the manual remote
- Visually follow the drone's descent to the ground

8. Post-Flight Checklist (With Deployment)

- Hold parachute by the lines and fold canopy to prevent wind from inflating it
- Turn off PRS-M200
- Turn off drone
 - a. Note: Dislodge Flight Termination System by pressing DJI M200 battery remove battery if drone is not turning off
- Disconnect PRS-M200 and bracket from the drone using quarter turns
- Verify that no components are missing

Maintenance & Care

Maintenance and inspection intervals of the AVSS PRS-M200 are required to maximize the safety of each flight and ensure proper functionality for parachute deployment whenever it may be required. The PRS-M200's Electronic Module is expected to reliably function for several parachute deployments so long as no damage is imparted to the module. The PRS-M200's Parachute Pod™ is intended as a single-use item that can be quickly removed and replaced in the field.

1. Post-Flight (Monthly)

1. Visually inspect the PRS-M200 to ensure there is no damage
2. Test the receptacles on the Electronic Module and Parachute Pod™
3. Test the manual remote

2. Transportation

1. Before transporting, ensure the safety pin is properly inserted
2. Always transport in a secure storage case

3. Storage

1. Always ensure power is off
2. Make sure the unit is clean and dry before putting in the case

4. Extended Storage Considerations

1. Store in a dry, room temperature location
2. Uninstall the AVSS PRS-M200 assembly down to the following separate components:
 - a. PRS-M200 Electronic Module
 - b. PRS-M200 Parachute Pod
3. Visually inspect the electrical connectors located on both the Electrical Module and the Parachute Pod. Check against signs of corrosion, dust/dirt buildup, wear, or any other types of abnormalities. Clean electrical contacts with rubbing alcohol and cotton swabs if necessary.
4. Inspect the Main Parachute and harness lines for:
 - a. Signs of moisture such as standing water or mold
 - b. Tears, rips, fraying and other signs of wear and damage
5. If any of the above defects are present during the annual inspection, contact AVSS for further information.

Frequently Asked Questions

1	How do I register my PRS-M200?	Go to https://www.avss.co/products/product-registration/
2	When does the ATS Arm?	35 meters
3	When does the Manual Remote Arm?	15 meters
4	When does the PRS-M200 return to a standby state?	After landing for 5 to 10 seconds and then the user will receive audio feedback that it has returned to the standby state
5	How many files can the microSD card hold?	Erase microSD card files after 200 flights
6	How do I check the power level?	Push the Sync button on the PRS-M200 to check the power level

Parachute Pod Deployment Procedures

To return a used and/or unused Parachute Pod™, an end-user may do so by sending the Parachute Pod™ directly to AVSS or by returning the Parachute Pod™ to their Authorized Dealer.

Sending to AVSS:

- Before sending the Parachute Pod™ to AVSS, contact customersupport@avss.co to request a shipping label.
- If you are purchasing a new Parachute Pod™, AVSS will send you a purchase link for a replacement Parachute Pod™, plus deposit.
- Once fully paid, AVSS will then send you the replacement Parachute Pod™.
- To return your Parachute Pod™ and receive your deposit, utilize the same box with the provided shipping label to send the Parachute Pod™ to AVSS.
- Once AVSS receives the Parachute Pod™ and completes the visual inspection, you will be notified and will receive your deposit within fourteen business days.

Sending to an Authorized Dealer:

- Contact your Authorized Dealer to notify them that you will be returning and/or requesting a new Parachute Pod™
- If you are purchasing a new Parachute Pod™, the Authorized Dealer will either send you a purchase link for a replacement Parachute Pod™, plus deposit, or accept payment at their physical location.
- Once fully paid and your Parachute Pod™ has been returned, the Authorized Dealer will then send you or directly provide you with the replacement Parachute Pod™.

Customer Support



Email: customersupport@avss.co
Telephone: Monday to Friday, excluding holidays
10:00 am Est to 4:00 pm Est
+1-844-852-0665



Appendix A: Drone & Payload References



Drone / Payload	Date	Link
DJI M200 V1	2018-11-20	https://dl.djicdn.com/downloads/M200/20181120R/Matrice_200_User_Manual_v1.4_EN.pdf
DJI M210 V1	2018-11-20	https://dl.djicdn.com/downloads/M200/20181120R/Matrice_210_210_RTK_User_Manual_v1.4_EN.pdf
DJI M210 RTK V1	2018-11-20	https://dl.djicdn.com/downloads/M200/20181120R/Matrice_210_210_RTK_User_Manual_v1.4_EN.pdf
DJI M200 V2	2019-12-13	http://dl.djicdn.com/downloads/m200_v2/20191213/M200_V2_UM_EN_v1.2_2.pdf
DJI M210 V2	2019-12-06	https://dl.djicdn.com/downloads/m200_v2/20191206/M210_V2_M210_RTK_V2_User_Manual_v1.6_EN_1206.pdf
DJI M210 RTK V2	2019-12-06	https://dl.djicdn.com/downloads/m200_v2/20191206/M210_V2_M210_RTK_V2_User_Manual_v1.6_EN_1206.pdf
SlantRange 4P	N.D.	https://slantrange.com/product-sensor/
Sentera AGx710	2019-11-26	https://sentera.com/wp-content/uploads/2018/03/Sentera_AGX710_Sensor_Lit4084A1.pdf
U10 Methane	2019-10-09	https://terra-1-g.djicdn.com/851d20f7b9f64838a34cd02351370894/others/EN-a5_U10%20Gas%20Detector_en_format_191009.pdf
Wingsland Z15	2019-09-16	https://terra-1-g.djicdn.com/851d20f7b9f64838a34cd02351370894/others/Z15_Spotlight_en.pdf
Zenmuse X4S	2018-11-07	https://dl.djicdn.com/downloads/zenmuse_x4s/20181107/Zenmuse+X4S+User+Manual+V1.4_EN.pdf
Zenmuse X5S	2018-04-20	https://dl.djicdn.com/downloads/zenmuse_x5s/20180420/Zenmuse+X5S+user+manual_v1.4_EN.pdf
Zenmuse X7	2018-07-18	https://dl.djicdn.com/downloads/zenmuse+x7/20180718/Zenmuse+X7+User+Manual+EN+v1.4.pdf
Zenmuse XT	2016-07-11	https://dl.djicdn.com/downloads/zenmuse_xt/en/Zenmuse_XT_User_Manual_V1.2_en_0708.pdf
Zenmuse XT 2	2018-05-11	https://dl.djicdn.com/downloads/Zenmuse%20XT%202/Zenmuse%20XT%202%20User%20Manual%20v1.0_.pdf
Zenmuse Z30	2018-10-08	https://dl.djicdn.com/downloads/zenmuse_z30/20180810/Z30_User_Manual_EN.pdf

Appendix B: IMU Calibration Instructions

A red flashing LED and a beeping sound coming from the PRS-M200 indicates that the IMU must be calibrated. There are two methods of calibrating the IMU on the PRS-M200, either by placing the PRS-M200 in the travel box or keeping the PRS-M200 on the drone. The preferred method is in the box; however, if the box cannot be located, performing the calibration on the drone is acceptable.

PRS-M200 IMU Calibration in the box		
Step 1	Remove the PRS-M200 from the brackets on the drone, but do not remove the module from the base plate.	
Step 2	Turn the PRS-M200 on and lay it on the PRS box, keeping it stationary for a couple of seconds until the LED flashes red and the PRS-M200 starts beeping.	

<p>Step 3</p>	<p>Place the PRS-M200 in its position in the PRS -M200 box.</p>	
<p>Step 4</p>	<p>Close the box</p>	
<p>Step 5</p>	<p>Rotate the box 90 degrees towards the latched end and allow the box to stand on this end for 5 seconds</p>	



<p>Step 6</p>	<p>Rotate the box 90 degrees in the opposite direction and allow it to stand on this end for 5 seconds</p>	
<p>Step 7</p>	<p>Bring the box back to the original position and rotate it to the right side 90 degrees and wait for 5 seconds.</p>	
<p>Step 8</p>	<p>Bring the box back to the original position and rotate it to the left side 90 degrees and wait for 5 seconds.</p>	



<p>Step 9</p>	<p>Bring the box back to the original position and leave it stationary for 20 seconds</p>	
<p>Step 10</p>	<p>If the calibration is successful three beeps will start from the PRS-M200 and the PRS-M200 will auto shutdown in 5 seconds.</p>	<p>If the calibration is unsuccessful the LED will continue to flash and the beeping will sound, go back to step 2 and re-calibrate.</p>

If the calibration is successful, the PRS-M200 LED will flash pink and blue and the module is ready to fly.

If the travel box cannot be found and calibration is needed, then use the following method on the drone.

<p>PRS-M200 IMU Calibration on the Drone</p>		
<p>Step 1</p>	<p>Remove the props from the drone and keep it on a level surface.</p>	

<p>Step 2</p>	<p>Turn on the PRS-M200. The PRS-M200 should be beeping and flashing red</p>	
<p>Step 3</p>	<p>Tilt the drone backward 90 degrees. Hold steady for 5 seconds.</p>	
<p>Step 4</p>	<p>Bring the drone back to level and then tilt it forward 90 degrees. Hold steady for 5 seconds.</p>	

<p>Step 5</p>	<p>Bring the drone back to level and then tilt it towards the right 90 degrees. Hold steady for 5 seconds.</p>	
<p>Step 6</p>	<p>Bring the drone back to level and then tilt it towards the opposite side 90 degrees. Hold steady for 5 seconds</p>	
<p>Step 7</p>	<p>Bring the drone back to level and leave it for 20 seconds.</p>	
<p>Step 10</p>	<p>If the calibration is successful three beeps will start from the PRS-M200 and the PRS-M200 will auto shutdown in 5 seconds.</p>	<p>If the calibration is unsuccessful the LED will continue to flash and the beeping will sound, go back to step 2 and re-calibrate.</p>